

LM108A/LH2108A

Precision Operational Amplifiers

Features

- Low input bias current — 2 nA
- Low input offset current — 200 pA
- Low input offset voltage — 500 μ V
- Low input offset drift — 5 μ V/ $^{\circ}$ C
- Wide supply range — \pm 3V to \pm 20V
- Low supply current — 0.6 mA
- High PSRR — 96 dB
- High CMRR — 96 dB
- MIL-STD-883B available

Description

The LM108A operational amplifiers features low input bias current combined with the advantages of bipolar transistor construction; input offset voltages and currents are kept low over a wide range of temperature and supply voltage. Raytheon's superbeta bipolar manufacturing process includes extra treatment at epitaxial growth to ensure low input voltage noise.

The LH2108 consists of two LM108 ICs in one 16-lead DIP. The "A" versions meet tighter electrical specifications than the plain versions. All types are available with 883B military screening.

Pin Assignments

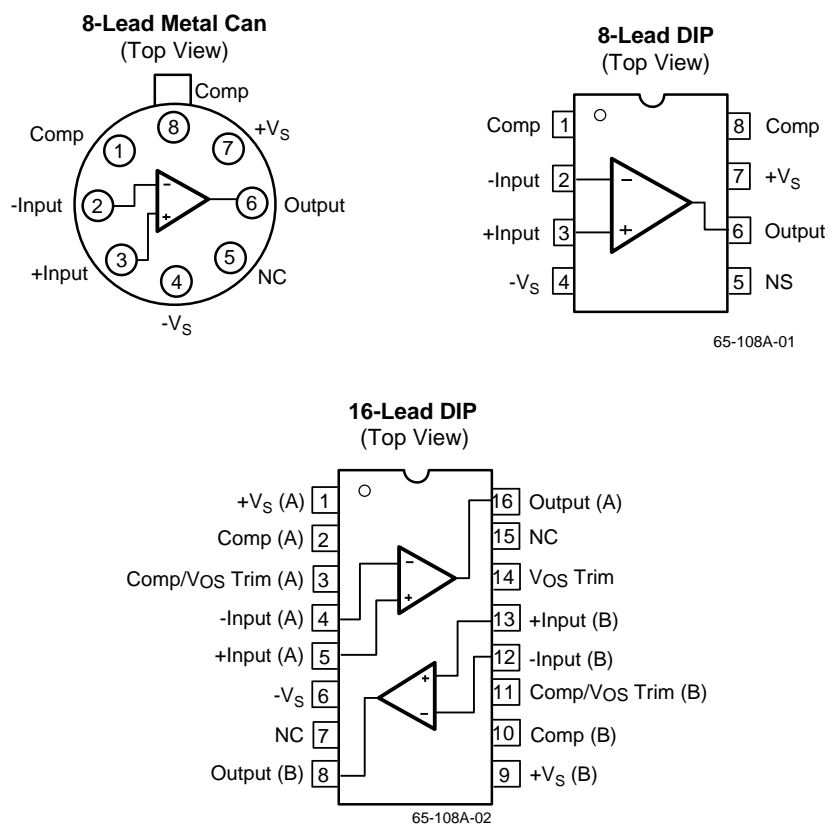

Absolute Maximum Ratings

Parameter	Min.	Max.	Units
Supply Voltage		± 20	V
Differential Input Current ¹		± 10	mA
Input Voltage ²		± 15	V
Output Short-Circuit Duration ²	Continuous		
Operating Temperature Range	-55	+125	°C
Storage Temperature Range	-65	+150	°C
Lead Soldering Temperature (60 seconds)		+300	°C

Notes:

- The inputs are shunted with back-to-back diodes for overvoltage protection. Therefore, if a differential input voltage in excess of 1V is applied between the inputs, excessive current will flow, unless some limiting resistance is provided.
- For supply voltages less than ± 15 V, the absolute maximum input voltage is equal to the supply voltage.

Thermal Characteristics

Parameter	8-Lead Metal Can	8-Lead Ceramic DIP	16-Lead Ceramic DIP
Maximum Junction Temperature	+175°C	+175°C	+175°C
Max. $P_{DTA} < 50^{\circ}\text{C}$	658 mW	833 mW	1042 mW
Thermal Resistance, θ_{JC}	50°C/W	45°C/W	60°C/W
Thermal Resistance, θ_{JA}	190°C/W	150°C/W	120°C/W
For $T_A > 50^{\circ}\text{C}$ Derate at	5.26 mW/°C	8.33 mW/°C	8.38 mW/°C

Electrical Characteristics

$\pm 5\text{V}$, $\leq V_S \leq \pm 20\text{V}$ and $T_A \leq +25^{\circ}\text{C}$ unless otherwise noted

Parameters	Test Conditions	LM108A/LH2108A			LM108/LH2108			Units
		Min.	Typ.	Max.	Min.	Typ.	Max.	
Input Offset Voltage			0.3	0.5		0.7	2.0	mV
Input Offset Current			0.05	0.2		0.05	0.2	nA
Input Bias Current			0.8	2.0		0.8	2.0	nA
Input Resistance ¹		30	70		30	70		MΩ
Large Signal Voltage Gain	$V_S = \pm 15\text{V}$, $V_{OUT} \pm 10\text{V}$, $R_L \geq 10\text{K}\Omega$	80	300		50	300		V/mV
Supply Current	Each Amplifier		0.3	0.6		0.3	0.6	mA

$\pm 5\text{V}$, $\leq V_S \leq \pm 20\text{V}$; $-55^{\circ}\text{C} \leq T_A \leq +25^{\circ}\text{C}$ unless otherwise noted

Input Offset Voltage			0.4	1.0		1.0	3.0	mV
Avg. Input Offset Voltage Drift ²			1.0	5.0		3.0	15	$\mu\text{V}/^{\circ}\text{C}$
Input Offset Current			0.1	0.4		0.1	0.4	nA
Avg. Input Offset Current Drift ²			0.5	2.5		0.5	2.5	$\text{pA}/^{\circ}\text{C}$
Input Bias Current			1.0	3.0		1.0	3.0	nA
Large Signal Voltage Gain	$V_S = \pm 15\text{V}$, $V_{OUT} = \pm 10\text{V}$, $R_L \geq 10\text{K}\Omega$	40	200		25	200		V/mV
Output Voltage Swing	$R_L \geq 10\text{K}\Omega$, $V_S = \pm 20\text{V}$	± 16	± 18		± 16	± 18		V
Input Voltage Range	$V_S = \pm 15\text{V}$	± 13.5			± 13.5			V
Common Mode Rejection Ratio	$V_{CM} = \pm 13.5\text{V}$, $V_S = \pm 15\text{V}$	96	110		85	100		dB
Power Supply Rejection Ratio	$V_S = \pm 15\text{V}$	96	110		80	96		dB
Supply Current	Each Amplifier			0.6			0.6	mA

Notes:

1. Guaranteed by input bias current specification.
2. Sample tested.

Typical Applications

The LM108 series has very low input offset and bias currents; the user is cautioned that printed circuit board leakages can produce significant errors especially at high board temperatures. Careful attention to board layout and

cleaning procedure is required to achieve the LM108A's rated performance. It is suggested that board leakage be minimized by encircling the input pins with a guard ring maintained at a potential close to that of the inputs. The guard ring should be driven by a low impedance source such as an amplifier's output or ground.

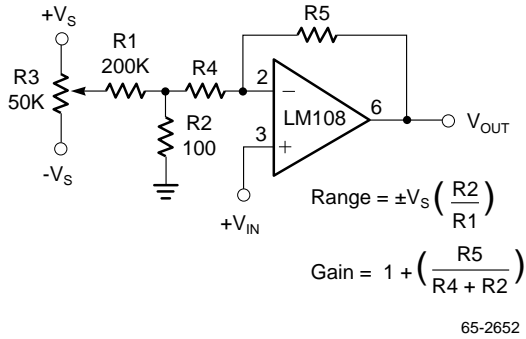

Figure 1. Offset Adjustment for Non-Inverting Amplifiers

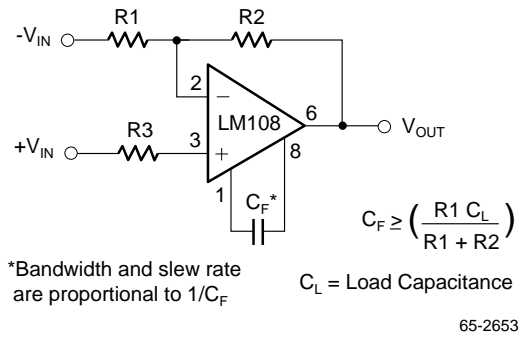

Figure 2. Standard Compensation Circuit

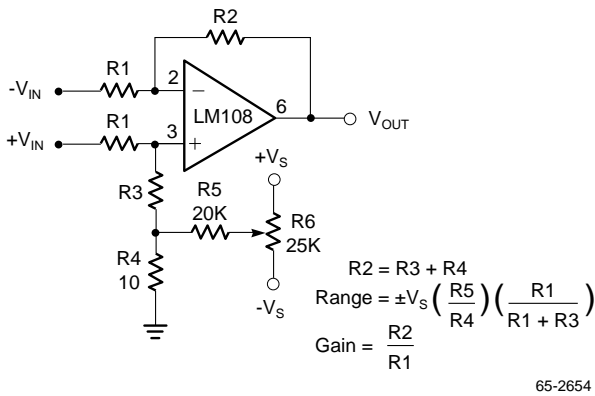

Figure 3. Offset Adjustment for Differential Amplifiers

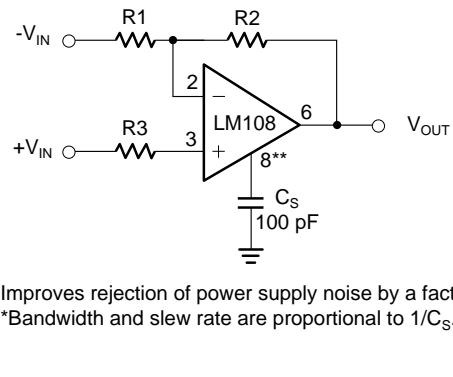

Figure 4. Alternate Frequency Compensation

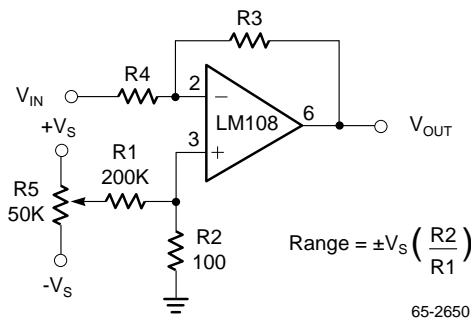

Figure 5. Offset Adjustment for Inverting Amplifiers

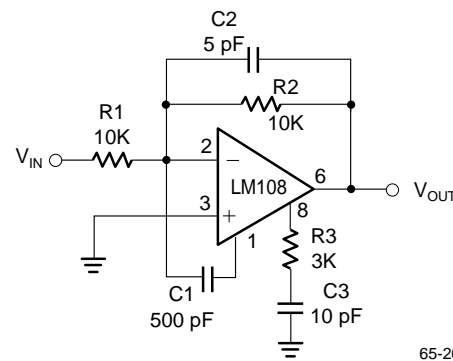

Figure 6. Feedforward Compensation

Mechanical Dimensions (continued)

8-Lead Ceramic DIP

Symbol	Inches		Millimeters		Notes
	Min.	Max.	Min.	Max.	
A	—	.200	—	5.08	
b1	.014	.023	.36	.58	8
b2	.045	.065	1.14	1.65	2, 8
c1	.008	.015	.20	.38	8
D	—	.405	—	10.29	4
E	.220	.310	5.59	7.87	4
e	.100 BSC		2.54 BSC		5, 9
eA	.300 BSC		7.62 BSC		7
L	.125	.200	3.18	5.08	
Q	.015	.060	.38	1.52	3
s1	.005	—	.13	—	6
α	90°	105°	90°	105°	

Notes:

1. Index area: a notch or a pin one identification mark shall be located adjacent to pin one. The manufacturer's identification shall not be used as pin one identification mark.
2. The minimum limit for dimension "b2" may be .023 (.58mm) for leads number 1, 4, 5 and 8 only.
3. Dimension "Q" shall be measured from the seating plane to the base plane.
4. This dimension allows for off-center lid, meniscus and glass overrun.
5. The basic pin spacing is .100 (2.54mm) between centerlines. Each pin centerline shall be located within ± 0.010 (.25mm) of its exact longitudinal position relative to pins 1 and 8.
6. Applies to all four corners (leads number 1, 4, 5, and 8).
7. "eA" shall be measured at the center of the lead bends or at the centerline of the leads when " α " is 90°.
8. All leads – Increase maximum limit by .003 (.08mm) measured at the center of the flat, when lead finish applied.
9. Six spaces.

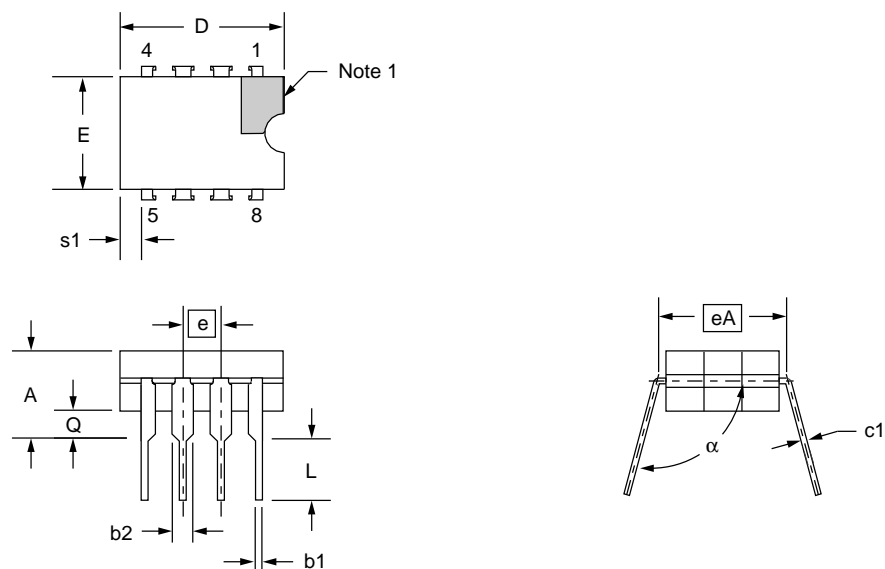

Mechanical Dimensions (continued)

16-Lead Ceramic DIP

Symbol	Inches		Millimeters		Notes
	Min.	Max.	Min.	Max.	
A	—	.200	—	5.08	
b1	.014	.023	.36	.58	8
b2	.050	.065	1.27	1.65	2
c1	.008	.015	.20	.38	8
D	.745	.840	18.92	21.33	4
E	.220	.310	5.59	7.87	4
e	.100 BSC		2.54 BSC		5, 9
eA	.300 BSC		7.62 BSC		7
L	.115	.160	2.92	4.06	
Q	.015	.060	.38	1.52	3
s1	.005	—	.13	—	6
α	90°	105°	90°	105°	

Notes:

1. Index area: a notch or a pin one identification mark shall be located adjacent to pin one. The manufacturer's identification shall not be used as pin one identification mark.
2. The minimum limit for dimension "b2" may be .023 (.58mm) for leads number 1, 8, 9 and 16 only.
3. Dimension "Q" shall be measured from the seating plane to the base plane.
4. This dimension allows for off-center lid, meniscus and glass overrun.
5. The basic pin spacing is .100 (2.54mm) between centerlines. Each pin centerline shall be located within $\pm .010$ (.25mm) of its exact longitudinal position relative to pins 1 and 16.
6. Applies to all four corners (leads number 1, 8, 9, and 16).
7. "eA" shall be measured at the center of the lead bends or at the centerline of the leads when " α " is 90°.
8. All leads – Increase maximum limit by .003 (.08mm) measured at the center of the flat, when lead finish applied.
9. Fourteen spaces.

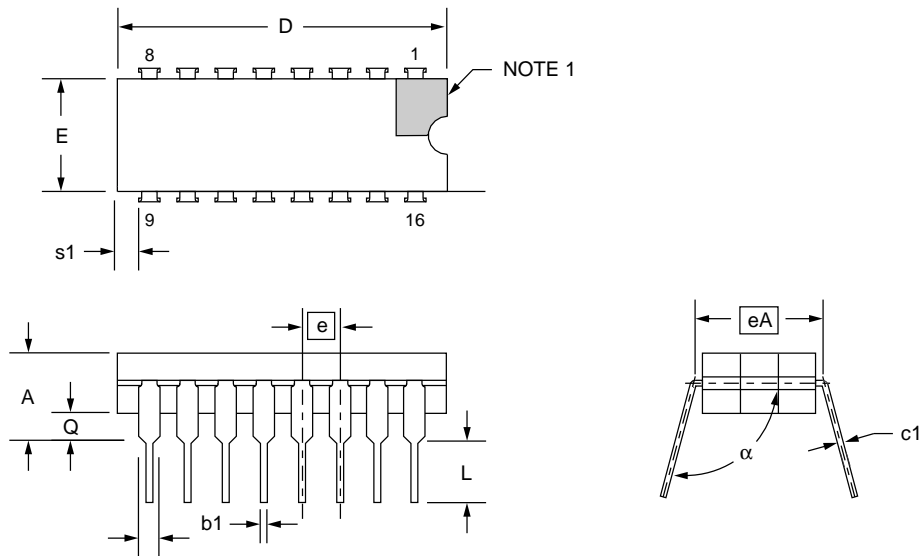

Ordering Information

Part Number	Package	Operation Temperature Range
LM108D	8-Lead Ceramic DIP	-55°C to +125°C
LM108D/883B	8-Lead Ceramic DIP	-55°C to +125°C
LM108AD	8-Lead Ceramic DIP	-55°C to +125°C
LM108AD/883B	8-Lead Ceramic DIP	-55°C to +125°C
LM108T	8-Lead Metal Can TO-99	-55°C to +125°C
LM108T/883B	8-Lead Metal Can TO-99	-55°C to +125°C
LM108AT	8-Lead Metal Can TO-99	-55°C to +125°C
LM108AT/883B	8-Lead Metal Can TO-99	-55°C to +125°C
LH2108D	16-Lead Ceramic DIP	-55°C to +125°C
LH2108D/883B	16-Lead Ceramic DIP	-55°C to +125°C
LH2108AD	16-Lead Ceramic DIP	-55°C to +125°C
LH2108AD/883B	16-Lead Ceramic DIP	-55°C to +125°C

Note:

1. /883B suffix denotes Mil-Std-883, Level B processing

The information contained in this data sheet has been carefully compiled; however, it shall not by implication or otherwise become part of the terms and conditions of any subsequent sale. Raytheon's liability shall be determined solely by its standard terms and conditions of sale. No representation as to application or use or that the circuits are either licensed or free from patent infringement is intended or implied. Raytheon reserves the right to change the circuitry and any other data at any time without notice and assumes no liability for errors.

LIFE SUPPORT POLICY:

Raytheon's products are not designed for use in life support applications, wherein a failure or malfunction of the component can reasonably be expected to result in personal injury. The user of Raytheon components in life support applications assumes all risk of such use and indemnifies Raytheon Company against all damages.

Raytheon Electronics
Semiconductor Division
350 Ellis Street
Mountain View, CA 94043
415.968.9211
FAX 415.966.7742